

Wichtig

Vor Gebrauch sorgfältig lesen
Aufbewahren für späteres Nachschlagen

Important

Lire avec attention avant utilisation
Conserver pour référence future

Importante

Leggere attentamente prima dell'uso
Conservare per riferimento futuro

Important

Read carefully before use
Keep for future reference





ENSO

Weitere Sprachen und Informationen unter: www.leggero.ch
More languages and informations under: www.leggero.ch
Autres langues et informations sous: www.leggero.ch

Leggero[®]
ENSO

www.leggero.ch

Table 3 — General meaning and use of colours in hazard severity panels

Background colour of panel	Contrast colour	Meaning/Use	Hazard severity panel illustration
Red	White	DANGER hazard severity panel to identify a high level of risk	
Orange	Black	WARNING hazard severity panel to identify a medium level of risk	
Yellow	Black	CAUTION hazard severity panel to identify a low level of risk	
The outer yellow border to the general warning sign is an option and may be omitted.			
NOTE The safety sign incorporated in these hazard severity panels is the general warning sign W001 specified in ISO 7010.			

Gefahr

Das Signalwort bezeichnet eine Gefährdung mit einem hohen Risikograd, die, wenn sie nicht vermieden wird, den Tod oder eine schwere Verletzung zur Folge hat.

Warnung

Das Signalwort bezeichnet eine Gefährdung mit einem mittleren Risikograd, die, wenn sie nicht vermieden wird, den Tod oder eine schwere Verletzung zur Folge haben kann.

Vorsicht

Das Signalwort bezeichnet eine Gefährdung mit einem niedrigen Risikograd, die, wenn sie nicht vermieden wird, eine geringfügige oder mässige Verletzung zur Folge haben kann.

Danger

Ce terme signale une situation dangereuse à niveau de risque élevé qui, si elle n'est pas évitée, entraîne la mort ou des blessures graves.

Avertissement

Ce terme signale une situation dangereuse à niveau de risque moyen qui, si elle n'est pas évitée, peut entraîner la mort ou des blessures graves.

Attention

Ce terme signale une situation dangereuse à niveau de risque faible qui, si elle n'est pas évitée, entraîne des blessures légères ou moyennement graves.

Pericolo

Questa espressione indica una situazione di minaccia con un elevato grado di rischio che, se non viene evitata, ha come conseguenza gravi lesioni o la morte.

Attenzione

Questa espressione indica una situazione di minaccia con un medio grado di rischio che, se non viene evitata, potrebbe avere come conseguenza gravi lesioni o la morte.

Cautela

Questa espressione indica una situazione di minaccia con un basso grado di rischio che, se non viene evitata, ha come conseguenza lievi o modeste lesioni.

Danger

This signal word indicates a hazard with a high level of risk which, if not avoided, will result in serious injury or death.

Warning

This signal word indicates a hazard with a medium level of risk which, if not avoided, may result in serious injury or death.

Caution

This signal word indicates a hazard with a low level of risk which, if not avoided, will result in minor or moderate injury.



ENSO

User's manual

ENSO

ENGLISH

Leggero Enso: Table of contents

1	Your new bicycle trailer	52	4.3.1	Fastening safety harnesses	60
1.1	Components	53	4.3.2	Safety flag	60
1.2	Modes	54	4.3.3	Handlebar	61
1.2.1	As a bicycle trailer	54	4.3.4	Securing loop	61
1.2.2	As a pushchair	54	4.4	Folding up the trailer	61
2	Safety information	54	4.5	Fitting the drawbar	62
2.1	Proper use as a BT*	54	4.6	Removing the drawbar	62
2.2	Warnings	55	4.7	Pushchair wheels	63
2.3	Proper use as a PC*	55	4.7.1	Folding out the pushchair wheels	63
2.4	Maintaining reliable operation	56	4.7.2	Folding in the pushchair wheels	63
2.5	Additional equipment	56	4.8	Parking brake	64
2.6	What kind of vehicles are suitable for towing the trailer?	56	4.8.1	Readjusting the brakes	64
2.7	Bicycle handling when towing a trailer	56	4.9	Cover	64
2.8	Safety checklist	56	4.9.1	Opening the cover	64
2.9	Cover	57	4.9.2	Closing the cover	64
2.10	Maintenance and care	57	4.10	Rain cover	65
2.11	Factors that increase wear	57	4.11	Rear compartment	65
2.12	Spare parts	58	4.12	Coupling and uncoupling	65
3	Parts included with the product and assembly	58	5	Various settings	66
	Assembly	58	5.1	Safety harnesses	66
4	Use	58	5.2	Suspension	66
4.1	Fitting the wheels	58	5.3	Settings for the KS-290 shock-absorbing strut	66
4.1.1	Removing the wheels	58	5.4	Setting the disc brakes	66
4.2	Unfolding the trailer	59			
4.3	Adjusting the safety harnesses	60			
				BT*: Bicycle trailer	
				PC*: Pushchair	

Your new 2016 bicycle trailer

10.38011.0003/4

General information

The Leggero Enso bicycle trailer is a high-quality children's trailer designed in accordance with all the latest research into ergonomics and optimal safety.



1.1 Components

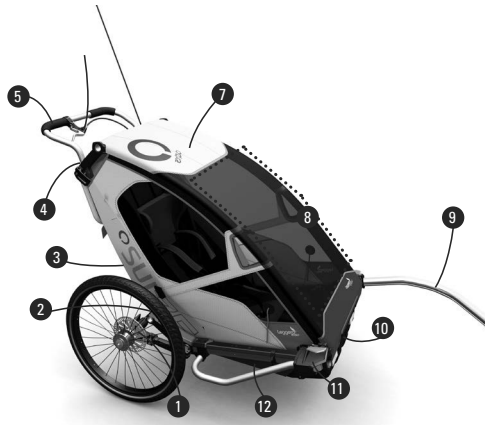

- 1 Disc brake
- 2 Suspension
- 3 Shock absorber
- 4 Pocket for small items
- 5 Adjustable handlebar
- 6 Parking brake
- 7 Rain cover
- 8 Cover (to prevent water spray/loose objects entering)
- 9 Drawbar
- 10 Impact guard
- 11 Syncro Lock folding mechanism
- 12 Quick Stroller pushchair wheel



- 1 Drawbar
- 2 Parking brake
- 3 Rear compartment
- 4 Ammortizzatore
- 5 Freno a disco
- 6 Telaio
- 7 Paracolpi

Suspension

Left-hand and right-hand wheels synchronised for stable roadholding when cornering. Adjustable suspension with rebound damping to prevent jerky rebounding of the suspension and effectively absorb shocks.

Brakes

Mechanical disc brakes with 140 mm disc diameter.

Left-hand and right-hand sides synchronised by means of a brake effort proportioning system integrated in the brake handle. The brake lever has a parking function to prevent the carriage from rolling away when it is set up as a pushchair.

“Syncro Lock” folding mechanism

Safety lock that can be released simply by pressing the operating elements on the left and right simultaneously when you wish to fold up the trailer.

“Quick Stroller” pushchair wheel unit

Pushchair wheels that can be used when you are travelling on foot, allowing you to convert the trailer into a pushchair in no time at all.

Combi cover

Integrated rain cover that can be quickly pulled over the trailer in the event of rain, and quickly put back again when it stops.

Handlebar

Height-adjustable handlebar that can be raised or lowered using quick releases and is rigidly connected to the trailer to allow precise steering.

Pocket for small items

Transparent, water-resistant pocket for storing mobile phones and other small items. When your mobile phone is stored in the small-item pocket, you can use it to play music into the inside of the trailer.

Rear compartment

Robust yet compact, foldable rear compartment with closure strap for securing the contents.

Seat unit

Generously proportioned seat with good lateral support and adjustable headrest that also adapts the five-point harness system to the child’s shoulder height when it is adjusted.



1.2 Modes

The Leggero Enso is a folding pushchair with suspension. It can be used in either of two configurations:

1.2.1 As a bicycle trailer

When the drawbar is fitted and the pushchair wheels are folded in, the Leggero Enso is a sporty single-seater trailer.



1.2.2 As a pushchair

When the pushchair wheels are folded out, the Leggero Enso becomes a practical pushchair/buggy thanks to the integrated handlebar and brake. The drawbar can easily be stowed on the pushchair.



2 Warnings

General regulations

Comply with the statutory regulations and recommendations pertaining to the use of bicycle trailers, and the transportation of children and cargo in them, that apply in the country in which the bicycle trailer is used.

Lighting:

Comply with national regulations. In addition, if you are intending to take the trailer on any trips or journeys that cross national borders, find out what local regulations apply in each of the countries you will be travelling in.



WARNING

- The person towing the trailer must be at least 16 years old.
- Using the trailer with a motorised vehicle – with the exception of e-bikes travelling no faster than 25 km/h – is forbidden.
- The Leggero Enso may only be coupled to the bicycle using the coupling supplied, or using a coupling provided by the manufacturer.
- To keep the risk of accidents and injury as low as possible, children must always be strapped in.
- Adjust the height-adjustable safety harnesses depending on the child's size.
- We strongly recommend that the child wears a safety helmet (comply with local regulations).
- Do not transport children less than 1 year old in the trailer
- Never leave children unsupervised in the trailer
- To ensure that the roll-over protection is effective, the child carried in the trailer must have sufficient headroom. When wearing the safety helmet, the child's head must not be any higher than the mark on the backrest.
- In particularly sunny weather, if the cover is closed, the inside of the trailer may become very hot, which can be dangerous for children.
- Only use e-bikes travelling no faster than 25 km/h
- Proceed in accordance with the information in the manual provided by the bicycle manufacturer.
- To tow the trailer, only use bicycles that do not have any technical faults and that comply with the local regulations

2.1 Safety information

Important: Keep the manual in case you need to consult it at a later date

Store this user's manual in a place that is accessible to all users at all times. Read this user's manual carefully from beginning to end. It contains information that you will need in order to use your bicycle trailer safely, and will help to prevent accidents and faults from occurring.

When using the carriage as a pushchair, some of the instructions and rules may not apply. See the relevant section in this regard.

- You can find the most important information on the product label on the trailer floor in front of the seat.
- There is a link to a video tutorial at www.leggero.ch.



2.2 Proper use: As a bicycle trailer

The trailer is not designed for off-road use and must not be used on off-road mountain bike trails. The manufacturer shall accept no liability in the event of accidents or faults of any kind resulting from improper use.

The trailer must not be improperly used or modified after purchase and no attachments of any kind must be fitted to the trailer unless expressly permitted by the manufacturer. Parts that were screwed on by the manufacturer may only be removed or replaced by the factory or an authorised specialist.

The manufacturer authorises the transportation of:

- One child whose height when wearing the safety helmet does not exceed the mark on the backrest
- One child weighing up to 17 kg
- Children up to 7 years of age
- Loads of up to 8 kg in the rear compartment
- Soft objects in the footwell up to 2 kg.

Drawbar:

- No additional loads must be attached to the drawbar.
- The drawbar must exert a downward load of no more than 8 kg on the bicycle's coupling.
- At the maximum load described in the rule above, a weight of 4 to 5 kg is exerted

Jogger set:

- This accessory has been developed by the manufacturer and is suitable for jogging and skating. The jogger set is not included in the scope of certification.

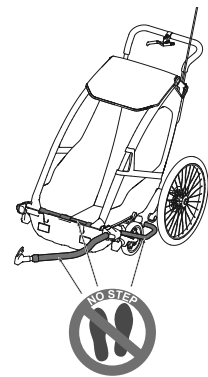
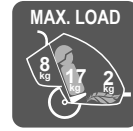

WARNING

The trailer's maximum weight of 40 kg must NOT be exceeded. In accordance with StVZO [German Road Traffic Licensing Regulations], the maximum permissible total weight of unbraked trailers is 40 kg.

WARNING

Weight loading/stepping on important parts of the trailer. The following elements may be stepped on/loaded with a maximum weight of 17 kg **when the trailer is stationary**:

- Left-hand and right-hand deflector tubes
- Drawbar
- Impact guard entrance edge (tube)
- Relatively high loads may permanently damage these parts and compromise the safety of the trailer.
- **The parts mentioned must not be loaded when the trailer is moving.**

2.3 Proper use: As a pushchair

The manufacturer authorises the transportation of:

- One child over the age of 6 months
- One child weighing up to 17 kg
- One child under the age of 3 years
- Loads of up to 8 kg in the rear compartment
- Soft objects in the footwell up to 2 kg

Additional uses:

- A safety baby seat is available as a separate accessory for children under 6 months
- A separate jogger set is available

WARNING

- Ensure that all locking mechanisms are locked before use
- To avoid injury, ensure that your child is not in the vicinity when you are folding and unfolding the pushchair.
- Do not allow your child to play with the pushchair.
- Always use the restraint system.
- This seat unit is not suitable for children under 6 months.
- Ensure that the parking brake is on when placing your child in the seat and when taking them out of the seat.
- This product is designed for children up to 3 years.
- This product is not suitable for jogging or skating.



2.4 What kind of vehicles are suitable for towing the trailer?



Using the trailer with a motorised vehicle – with the exception of e-bikes travelling no faster than 25 km/h – is forbidden.

To prevent water from splashing up and loose objects from getting into the trailer, fit splash guards/mudguards to the bicycle.

We recommend fitting rear-view mirrors to the bicycle.

The towing bicycle must have both a front and a rear brake.

The coupling must be fitted no higher than 400 mm above the ground.

2.5 Bicycle handling when towing a trailer

The trailer is not designed for off-road use and must not be used on off-road mountain bike trails.

Bicycles towing a trailer behave differently when braking and cornering. Before using the trailer in traffic, take it to a suitable off-road location and familiarise yourself with the differences in the way the bicycle handles when towing the trailer.

Take note, in particular, of the fact that the braking distance is increased by having the trailer attached.

To prevent the trailer from swinging out or overturning, it is important to make adjustments to the way you cycle. It is important to adjust your speed, particularly on unmade roads or paths.

Avoid taking the trailer on very steep roads or paths.

2.6 Safety checklist

Before using your trailer for the first time, please re-read the general safety information (see 2.2). Carefully read through the information on the components that are fitted to the trailer (brakes, shock absorber, etc.).

Whenever you wish to use the carriage as a bicycle trailer, always check the following:

- Are the stop bolts for the wheels seated securely and correctly?
- Is the folding mechanism securely engaged **ON BOTH SIDES**?
- Is the trailer coupling correctly fitted?
- Has the drawbar been correctly secured using the securing strap and pin?
- Recommended tyre pressure: 3 bar
- Have you complied with the maximum permissible loading of 17 kg on the seat, 8 kg in the rear compartment and 2 kg in the footwell?
- Is the suspension correctly adjusted for the load it is carrying?
- Is the bicycle free from technical faults (particularly brakes, steering and tyres)?
- Is the child correctly and securely strapped in?
- Are you and the child wearing safety helmets?
- Is the safety flag fitted?
- Are your lights and reflectors correctly fitted?
- Are the pushchair wheels properly folded in?

Every month:

- Check the drawbar, coupling and flexible connection shank for damage, scoring or loose fastenings
- Check the frame rods and parts for damage, cracks or loose fastenings
- Check the tyres for wear and cracks
- Check the rims for distortion and cracks
- Check the brake pads for wear, and replace them if necessary (see 5.4)
- Check the tension of the brake cables and check them for corrosion; if necessary, readjust them or replace them
- Check the cover, fabric-covered sections, child seat and harness system for cracks, signs of wear and missing or damaged parts
- Check that the suspension is working correctly (use the handlebar to compress the shock absorber in order to check that its stroke is unobstructed); if it is not working correctly, contact the manufacturer
- Check the wheel bearings and ball lock pins for wear and corrosion

2.7 Cover

WARNING

The cover included with the product must be fitted and closed when the carriage is being used as a bicycle trailer.

- The fabric will change colour over time. It may turn a few shades darker.

2.8 Maintenance and care

Maintenance: All joints and moving parts are maintenance-free.

Please note: If you lubricate any of the parts, only use silicone-based oils.

Care: Combi cover: Washable at temperatures of up to 40 °C. To clean the combi cover, just use soapy water and a soft cloth or sponge. The seat cushions can be removed to facilitate cleaning.

The brake cables can be readjusted and the brake pads can be replaced if they are badly worn; to do this, refer to the separate manual provided by the manufacturer (see 4.8.1/5.4)

You can also find important information on maintenance and care on the product page at www.leggero.ch.

Maintaining reliable operation

To ensure that the product operates reliably even after years of use, it is important to comply with the following instructions:

- Have the trailer checked regularly (at least every three years) by a specialist workshop.
- Aluminium parts are susceptible to deformation and cracking. Have any bent aluminium parts replaced immediately.

WARNING

- NEVER modify structural parts on your trailer
- Risk of breakage: NEVER bend back deformed or bent aluminium parts.
- Plastic parts may become brittle as a result of exposure to the weather and to UV radiation. The better protected the trailer is from these factors, the longer its service life will be.
- Replace cracked or damaged parts (or have someone else replace them) immediately
- We recommend replacing the coupling's polyurethane joint every five years.
- Have any badly corroded steel parts replaced immediately.



Please note

To prevent damage to the materials, never use abrasive cleaning products or cleaning products containing solvents such as acetone, toluene, etc.

2.9 Additional equipment

Only use genuine Leggero accessories

A wide range of accessories is available for the Leggero Enso. Find out what accessories are available from your dealer or contact the manufacturer directly, or alternatively visit the website at www.leggero.ch. You can also request a list of all the accessories that are currently available.

Separate couplings are available as accessories for use with additional bicycles.

2.10 Factors that increase wear

Factors affecting wear	Components	Cover	Seat	Fabric linings	Windows	Wheels, hubs and spokes	Tyres ⁵	Trailer towbar and hitch	Plastic parts	Aluminium parts
Load due to:	Passengers		x			xx	x	x	xx	xx
	Luggage	x		xx	x	xx	x	x	xx	xx
Riding style	Abruptness of acceleration and braking		x	x		x	x	xx	x	x
	Fast cornering		x		x	xxx	xxx	xxx	x	x
Weather effects	UV light	xx ¹	x	xx ²	xx ¹		x		xx ²	
	Damp	xx ³	xx	xx	x			x	x	
	Dirt	xx	xx	xx	xx	x	x	x	x	
	Temperature	x ⁶	x	x ⁶	x ⁶			x	xx	
	Salty air	x	x	xx	x	xxx	xx	xx	x	xx
	Contact with saltwater	xx	xx	xx	xx	xx	xx	xx	x	x
	Roads gritted with salt	xx	xx	xx	xx	xx	xx	xx	x	x
Storage	x ³	x ³	x ³	x ³						

x: Moderate effect on wear
 xx: Marked effect on wear
 xxx: Substantial effect on wear

- 1 Avoid exposure to strong sunlight wherever possible
- 2 Avoid long periods of exposure to sunlight wherever possible
- 3 To prevent mould formation, only pack away dry
- 4 Hanging up the items will prevent any wear
- 5 Regularly check the air pressure
- 6 Cold: at temperatures under 0° Celsius the material becomes brittle and may even break under certain circumstances

2.11 Spare parts

PLEASE NOTE

- Spare parts are available so you can keep your trailer in perfect working order.
- Only use genuine parts from the manufacturer.

- Combi cover
- Seat cushion/head cushion
- Syncro Lock operating buttons
- Spare clips for securing pushchair wheels (fork clip set)
- Pushchair wheel unit
- Flag
- Wheel I/wheel II (left/right)
- Shock absorber
- Handlebar

3 Parts included with the product and assembly

Parts included with the product

- Trailer (folded)
- Drawbar
- Wheels (left-hand wheel/right-hand wheel marked)
- 2 ball lock pins with an orange cap
- Handlebar
- Flag
- 1 red rear light
- Nabecco Uni 12
- User's manual

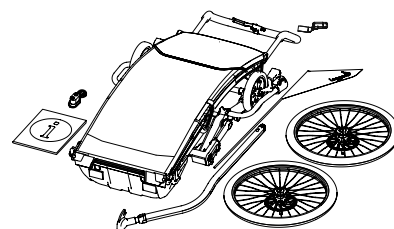

Assembly

- Take all the parts out of the packaging and check that they are all there.
- Slot the wheels into the wheel mounts with the help of the ball lock pin (see 4.1).
- Unfold the trailer (see 4.2 "Unfolding the trailer").
- Fit the handlebar and secure it in place (see 4.3.3. "Handlebar").
- Fit the red rear light on the left-hand side (direction of travel) of the handlebar (see 4.3.3).
- Fit the safety flag (see 4.3.2 "Safety flag").
- Fit the drawbar (see 4.5 "Fitting the drawbar").
- Adjust the height of the headrest (see 4.3 "Adjusting the safety harnesses").
- Adjust the suspension spring pre-load depending on the load that the trailer is to carry (see 5.2 "Suspension").
- Before using the trailer for the first time, run through the safety checklist (see 2.6 "Safety checklist").

4 Use

4.1 Fitting the wheels

Fit the wheels as follows: (Left-hand and right-hand wheels)

- Take the ball lock pins and wheels out of the packaging.
- Push each wheel onto the centre of the brake.
- Push in the ball lock pins until they lock into place.
- Check that the wheels are securely in place.

4.1.1 Removing the wheels

You can remove the wheels in the opposite order:

- The wheels can be removed from the trailer to save even more space when storing it.
- Press the button in the centre of the hub and pull out the axle at the same time.
- Pull the wheel out towards the back (contrary to the direction of travel).

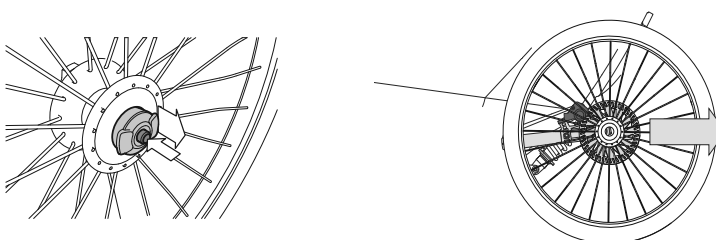

4.2 Unfolding the trailer

The Syncro Lock system is equipped with a safety mechanism and can only be opened or closed if both elements are being operated correctly at the same time.

- 1 Take hold of the Syncro Lock elements.
- 2 Pull the Syncro Lock elements forward; the carriage will tilt forwards and the front tray will make contact with the ground.
- 3 Pull the Syncro Lock elements further forward and the carriage will start to unfold. As it does this, the cover fabric will become tensioned so you will need to use a little force. Continue swinging the elements open until they come to rest on the impact guard.
- 4 Take hold of both the black Syncro Lock elements and at the same time push them down until they engage in the front tray. Check that BOTH Syncro Lock elements are properly attached to the front tray: There should not be a gap between the Syncro Lock elements and the front tray.
- 5 The operating buttons must be horizontal.

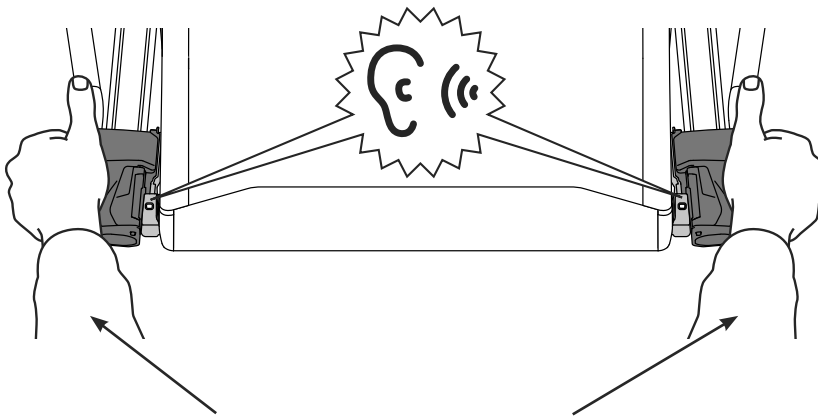
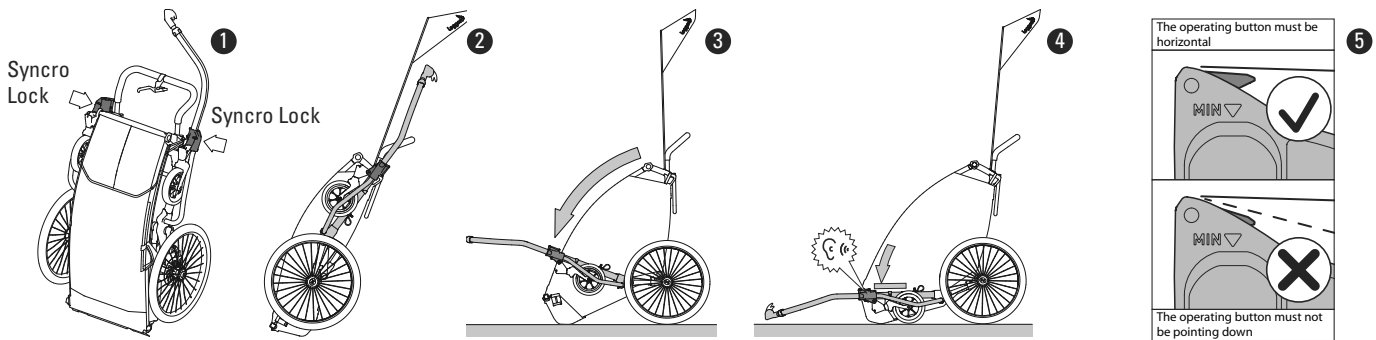

Push down in both places at the same time and make sure that the elements lock into place properly – if they do engage properly, you should be able to hear them click into place

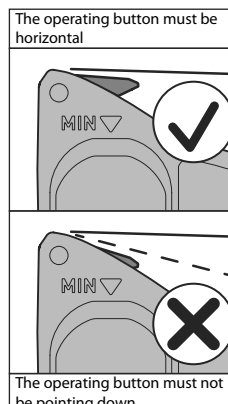
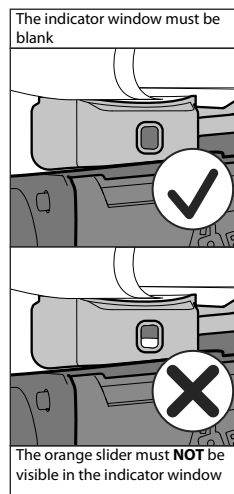
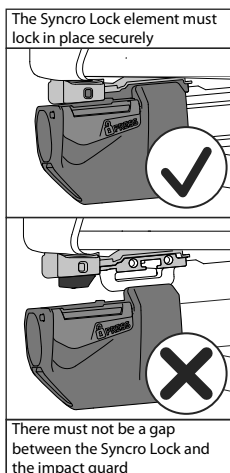

4.3 Adjusting the safety harnesses

To keep the risk of accidents and injury as low as possible, children must always be strapped in.

HARNES ANGLE:

- 1 To ensure that your child is as safe as possible, the harnesses should run horizontally across their shoulders (or at an angle of no more than 15°), as shown in the illustration.
- 2 To achieve this, you will need to adjust the height of the shoulder harnesses: The harnesses are connected to the headrest.
 - Detach the headrest by pulling it away from the velcro on the back section. The headrest can now be moved up or down, along with the shoulder harness.
 - Secure the rests again at the correct height. The harness angle is crucial. The headrest must not be secured any higher than the maximum height. Look for the mark on the seat to guide you.
- 3 Check that the tightness of the safety harnesses is correct. The harness should be relatively tight but should still sit comfortably on the body. To achieve this, you can adjust the width of the harness at both ends.
- 4 To ensure that the roll-over protection is effective, children carried in the trailer must have sufficient headroom (recommendation: At least 5 cm). When wearing the safety helmet, the child's head must not be any higher than the "max." mark on the seat.
- 5 We strongly recommend that the child wears a safety helmet (comply with local regulations).

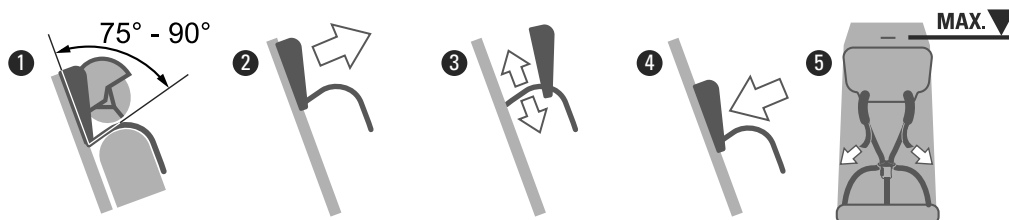

4.3.1 Fastening safety harnesses

- Make sure that the harnesses are positioned correctly. The harnesses must run over the shoulders and legs. The harness buckle must be positioned between the legs.
- Connect the left- and right-hand latch plates to one another.
- Insert the connected latch plates into the harness buckle. This is the only way to ensure that the harness buckle is securely fastened. You will be able to clearly hear the latch plates lock into place.
- Check that the harnesses are sitting tightly and that the harness buckle is securely fastened.

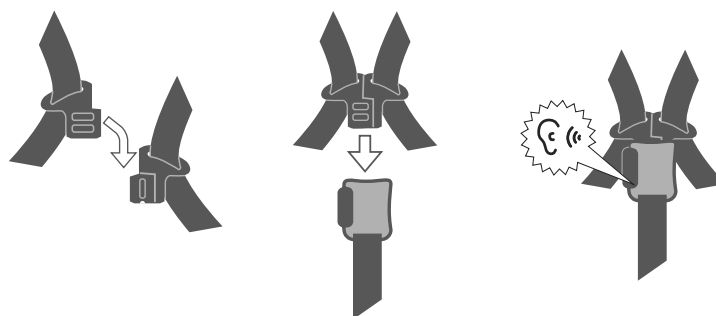
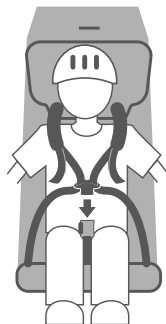

4.3.2 Safety flag

- Insert the end of the safety flag into the opening provided. The flag should protrude from the left-hand side in the direction of travel. Ensure that the flag is securely in place by pushing it down once more.

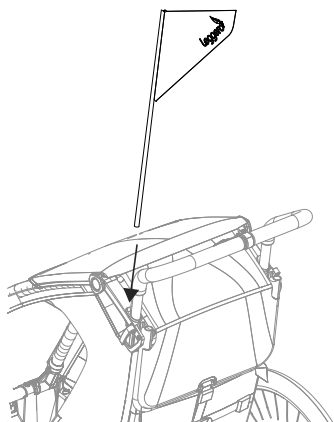

4.3.3 Handlebar

Fitting:

- Open up the quick releases on both sides of the trailer.
- Insert the handlebar into the slots provided.
- Push the locking buttons on both sides and insert the handlebar in the direction indicated.
- The handlebar will click into the highest possible position, which prevents it from being pulled out.
- Fit the rear light directly behind the bend in the handlebar (rear light certified in accordance with StVZO [German Road Traffic Licensing Regulations]).

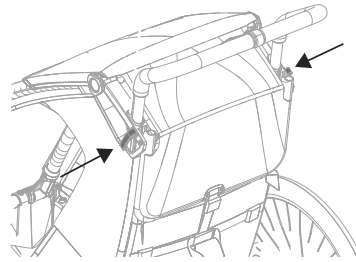
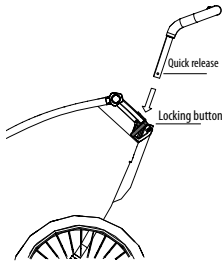

Securing the handlebar at a particular height setting:
Close the quick releases on both sides again

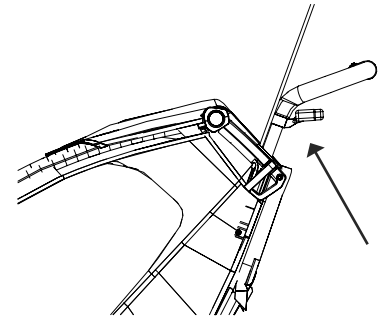

Fitting the rear light
Directly below the bend, pointing backwards

Adjusting the height:

The handlebar can be lowered further and adjusted:

- To do this, open up the two quick releases.
- Push in the two locking buttons (located at the quick-release levers).
- Push the handlebar down and set it at the required height.
- Close the two quick releases.

Readjusting:

- If the quick releases ever lose tension, you can use the nuts on the inside to readjust the tension.
- Carefully retighten them only to the point at which the desired clamping tightness is achieved again when the quick releases are closed.

CAUTION

Risk of tipping: Do not add any extra weight to the handlebar.



ENGLISH

4.3.4 Securing loop

- On the right-hand side of the trailer, there is an elastic securing loop near the handlebar.
- When the trailer is folded up, this elastic securing loop is stretched over the Syncro Lock elements to prevent the trailer from unfolding itself.
- The same elastic loop can be used to secure the drawbar to the side of the carriage when it is being used as a pushchair. To do this, see 4.6 "Removing the drawbar".

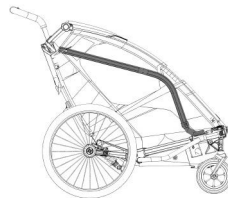
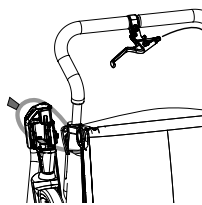

4.4 Folding up the trailer

The Syncro Lock system can only be opened when the two orange buttons are pressed at the same time. This safety mechanism means that the folding mechanism can only be activated when using both hands.

- Ensure that the pushchair wheels are folded in (see 4.7.2 "Folding in the pushchair wheels").
- Press the orange operating buttons on both Syncro Lock elements AT THE SAME TIME > the folding mechanism is now released.
- By moving the black Syncro Lock elements upwards, the carriage will start to fold in. Hold the front tray using your knee.
- Completely fold up the trailer and secure the left-hand (when seen in the direction of travel) Syncro Lock element using the loop; this prevents the trailer from folding out inadvertently when being transported.
- In this position, the trailer can be rolled as a folded package.
- To reduce the storage volume further, the wheels can be removed (see 4.1.1).

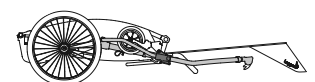
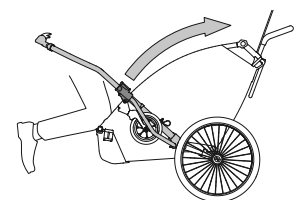
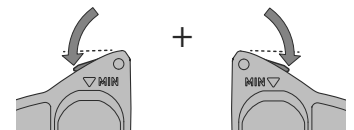

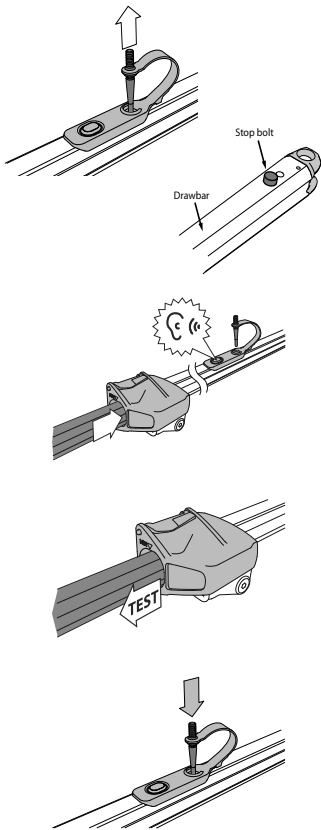

4.5 Fitting the drawbar

- If the lock pin is already inserted, this must first be removed
- The drawbar has a stop bolt that must be pressed lightly to insert it.
- **Fully** insert the drawbar until it engages. Ensure that you hear the stop bolt click into place. Check that it is fitted correctly by **pulling backwards** on the drawbar.
- If the drawbar is correctly engaged, the lock pin must now be fitted. If the lock pin cannot be positioned correctly, the drawbar is not properly engaged.
- The safety label must be completely inserted into the slot.

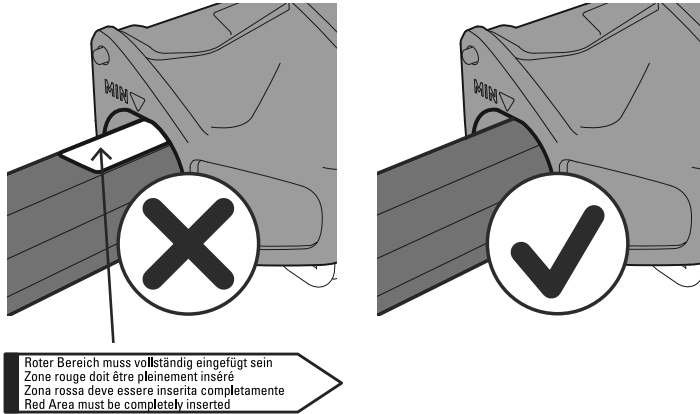

WARNING

Before you pull away, the drawbar must always be positioned correctly and secured fully. **If the red warning marker is visible, the drawbar is not fitted correctly.**

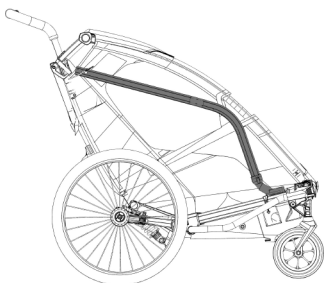
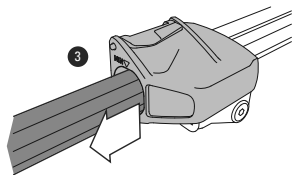
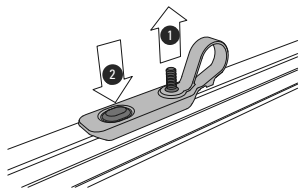

4.6 Removing the drawbar

- 1 Remove the lock pin by pulling it upwards.
- 2 Push in the stop bolt using the button on the orange operating element.
- 3 Keep the stop bolt pressed in, and simultaneously remove the drawbar by pulling it forwards.

Stowing the drawbar

- Attach the drawbar with coupling to the strut, just as on the bicycle coupling.
- Close the coupling.
- Secure the upper end of the coupling using the strap.

4.7 Pushchair wheels

The front wheels (pushchair wheels) can be folded in or out for use in the various modes. (If the carriage is only to be used as a bicycle trailer, the wheels can also be completely removed.)

4.7.1 Folding out the pushchair wheels

- Tip the trailer back sufficiently.
- Using your foot, push the wheel out of the catch.
- The wheel engages in the front position with an audible "click".

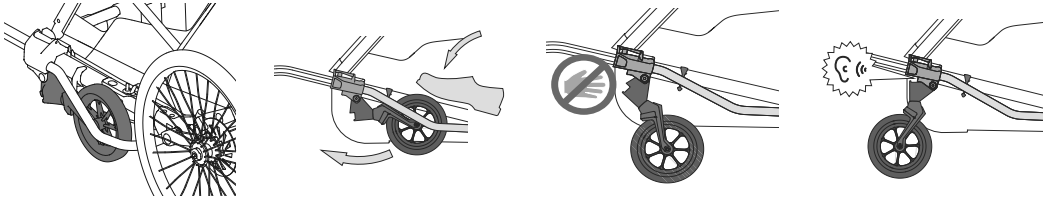

CAUTION

Risk of trapping fingers. Do not fold out the wheels by hand, and keep hands and fingers away from the closing area.

4.7.2 Folding in the pushchair wheels

- Ensure that the fork points forward.
Please note:
Pull the trailer backwards briefly so that the wheels align themselves automatically.

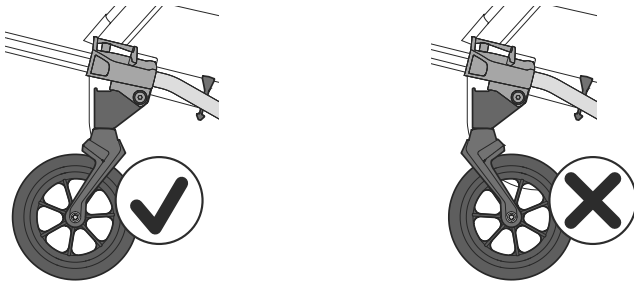

- Press the release button and tilt the wheels backwards.
- Click the wheels into place.

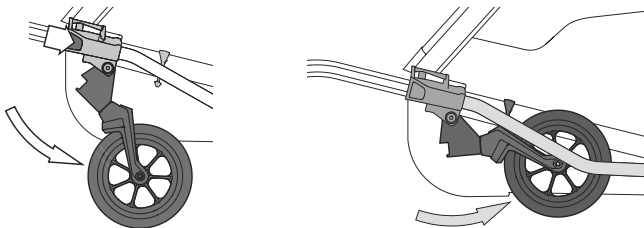

CAUTION

When the carriage is being used as a trailer, the front wheels must always be folded in when the trailer is in motion.
Both wheels must always be either folded in or folded out.

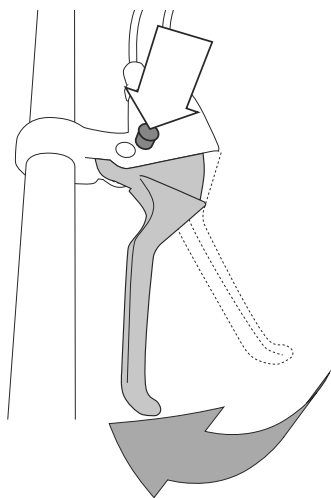

4.8 Parking brake

For use as a pushchair, the carriage is fitted with a hand brake that can also be locked to prevent the carriage from rolling away.

To apply the brake:

To apply the parking brake, pull the brake lever and then push in the locking button. The brake lever can now be released, and the brake remains locked.

To release the brake:

To release the parking brake, pull the brake lever. The locking button is released and the carriage can roll freely.

WARNING

If the brake pads become worn, the brake may no longer prevent the carriage from rolling away, despite the brake lever being fully engaged. Therefore, before every use, the parking brake must be checked to ensure it is working properly by pushing the carriage whilst the parking brake is engaged. If the braking is insufficient, the brake cable must be readjusted or the brake pads replaced. To do this, see the relevant section, 5.4

4.8.1 Readjusting the brakes

The braking system is set to a standard setting at the factory. Before first use, this brake setting must be checked to ensure that it is sufficiently effective when the parking brake is engaged.

If, due to strain or wear and tear, the effectiveness of the parking brake worsens over time, the brake tension can be increased again.

- To do this, release the tension on the brake lever.
- Undo the lock nut on the cable(s) concerned.
- Slightly unscrew the adjusting screw from the handle; the more this is unscrewed, the higher the tension on the brake cable.
- Apply the parking brake and test its effectiveness.
- If required, continue to turn the adjusting screw.
- Screw the lock nut back to secure the adjusting screw in the desired position.

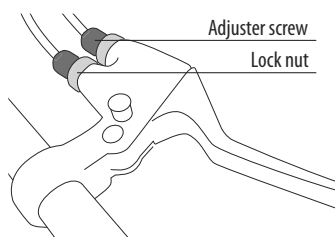

4.9 Cover

WARNING

When the carriage is being used as a bicycle trailer, the cover must be closed when the carriage is in motion.

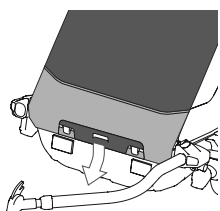

4.9.1 Opening the cover

- Hold the handle on the bottom of the cover and pull downwards so that it releases from the hooks. Unfold the cover upwards.



4.9.2 Closing the cover

- Hold the handle on the cover and pull downwards.
- Clip the cover onto the two hooks on the impact guard.

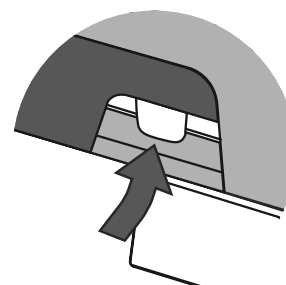
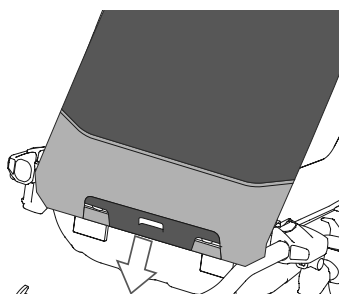

4.10 Rain cover

The carriage has an integrated rain cover under the roof hood. This can be tucked away into the upper hood. The rain cover is fixed in position at the bottom using press studs.

When not in use, the rain cover must be tucked away under the roof hood.

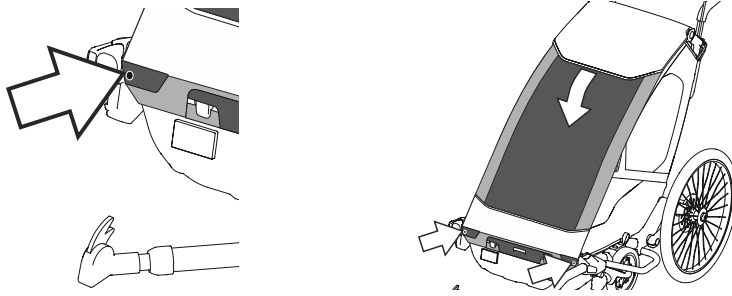

4.11 Rear compartment

The carriage has a rear compartment so that cargo can be conveniently transported.

The rear compartment must carry no more than 8 kg so that the carriage's centre of gravity is not shifted too far back.

The rear compartment has a lashing strap. By pulling downwards on this strap, the load can be prevented from moving around. This is particularly important when riding, to ensure that the trailer is in a stable position.

To loosen the strap, pull the tab downwards. When not in use, the rear compartment can be folded away. To do this, fold the upper bar downwards and tighten the lashing strap.

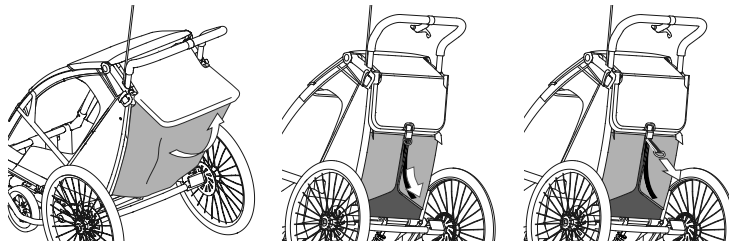

4.12 Coupling and uncoupling

Coupling

- Open the coupling lever. Using your thumb, push the shorter lever upwards and fully flip it forwards.
- Slide the coupling sideways over the towing part on the coupling plate.
- Close the coupling. Flip the longer lever backwards and then press down until the coupling snaps into place.
- Caution: The coupling lever must be fully snapped into place.
- Check that it is held in place by pulling against it sideways.
- Loop the straps for the catch mechanism around the bicycle frame and secure them with the clamping buckle.

Caution: For safety reasons, always fit the catch mechanism.

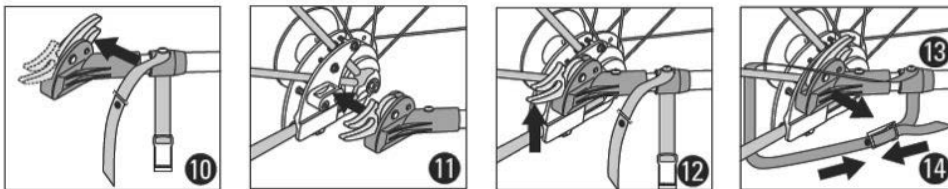
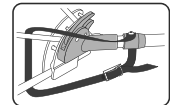

Uncoupling

- Undo the catch mechanism.
- Open the coupling (see above).
- Pull the coupling housing to one side.
- Close the coupling again.

Please note: To avoid damage, store the trailer only with the coupling closed.

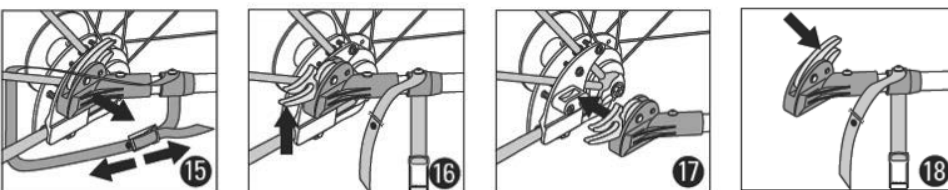

5 Various settings

The Leggero Enso has various adjustable elements. For maximum safety and optimal performance, the settings must always be correct.

5.1 Safety harnesses

Before every journey, safety harnesses must be adjusted to fit the passenger in accordance with 4.3/4.3.1, if they are not already correctly adjusted.

5.2 Suspension

The suspension spring pre-load can be adapted to the weight of the carriage and its load. The suspension can only function as described if it is optimally adjusted.

5.3 Settings for the KS-290 shock-absorbing strut

The screw spacing on the up-ended trailer is 150 mm. This length can be easily determined using a calliper or a yard stick.

If the carriage is set correctly when loaded (incl. child), the screw spacing should be approx. 141 mm.

If this value is not achieved, the spring pre-load must be adjusted.
The spring pre-load length can also be determined by re-measuring.
This distance must be between 30 and 35 mm.

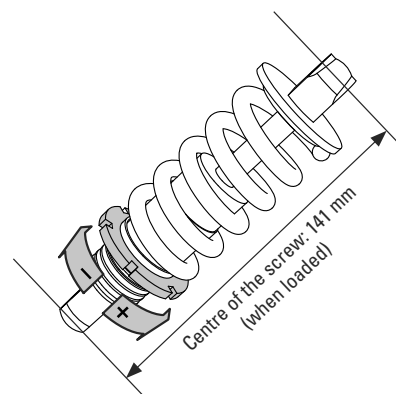
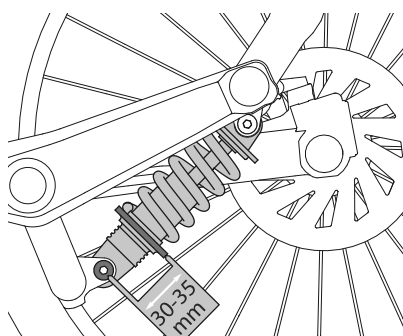

5.4 Setting the disc brakes

The manufacturer's original instructions are enclosed. Further information can be found in section 2.8, "Maintenance and care", and on the product page at www.leggero.ch



Brüggli Industrie
Hofstrasse 3+5
CH-8590 Romanshorn
T +41 71 466 95 95
F +41 71 466 95 96
info@leggero.ch
www.leggero.ch

Brüggli GmbH
Turmstrasse 11
D-78467 Konstanz
T +49 7531 9113993
F +49 7531 9113995
info@leggero.de
www.leggero.de